

90% GAS FURNACE JOBSITE INFORMATION SHEET

OWNER:

Name: _____
Street: _____
City: _____ Zip: _____
State/Province: _____ Phone: _____

DATE: _____

PROBLEM DESCRIPTION:

SERVICING CONTRACTOR:

Name: _____
Street: _____
City: _____ Zip: _____
State/Province: _____ Phone: _____

DISTRIBUTOR:

Name: _____
Street: _____
City: _____ Zip: _____
State/Province: _____
Phone: _____

PRODUCT INFORMATION:

Furnace Model Number: _____
Evaporator Model Number: _____
Installation Date: _____

Serial #: _____

Serial #: _____

TEMPERATURES: (Figure 1)

- T1-Vent Temperature = _____
- T2-Return Air = _____
- T3-Supply Air = _____
- Temperature Rise (T3-T2) = _____
- Gas Pipe Diameter = _____
- Gas Pipe Length = _____
- LP or Natural Gas = _____
- Burner Orifice Size = _____

HIGH VOLTAGE CIRCUIT READINGS: (Figure 3)

① to ⑦ - Line Voltage _____
② to ⑦ - IBM _____
③ to ⑦ - IDM _____
④ to ⑦ - Transformer _____
⑤ to ⑦ - L1 to Neutral _____
① to ⑪ - L1 to Earth Ground _____
⑦ to ⑪ - Neutral to Earth Ground _____
⑧ - Humidifier Term. Continuity _____
⑨ - EAC to Neutral _____
⑩ - HSI Voltage during "warm-up" _____

PRESSURES (Furnace Running): (Figure 1)

- P1-Manifold = _____
- P2-Inlet Gas = _____
- P3-Vent Pressure Switch = _____
- Drain Pressure Switch (for GRA/GRJ only) = _____

LOW VOLTAGE CIRCUIT READINGS: (Figure 4)

① to ⑨ - Transformer Control Voltage _____
② - Fuse _____
③ - MRLC & LC a: _____ b: _____ c: _____
④ - Gas Valve _____
⑤ - Vent Pressure Switch _____
⑩ - Drain Pressure Switch _____
⑦ - Flame Sensor Micro Amp _____
⑧ - Heat Assisted Limit _____

EXHAUST VENT: (Figure 2)

- Type = _____
- Diameter = _____
- Length = _____
- Number of 90's = _____
- Number of 45's = _____
- Term. Length = _____

OTHER NECESSARY DATA: (Figure 2)

- Is return air intake sealed and terminating outside furnace area? _____
- Fault Code Number of Flashes (Fig. 1) _____
- Electronic Thermostat? Yes No

INTAKE VENT: (Figure 2)

- Type = _____
- Diameter = _____
- Length = _____
- Number of 90's = _____
- Number of 45's = _____
- Term. Length = _____
- Sep. Distances = _____

REQUESTED BY: _____



Figure 1

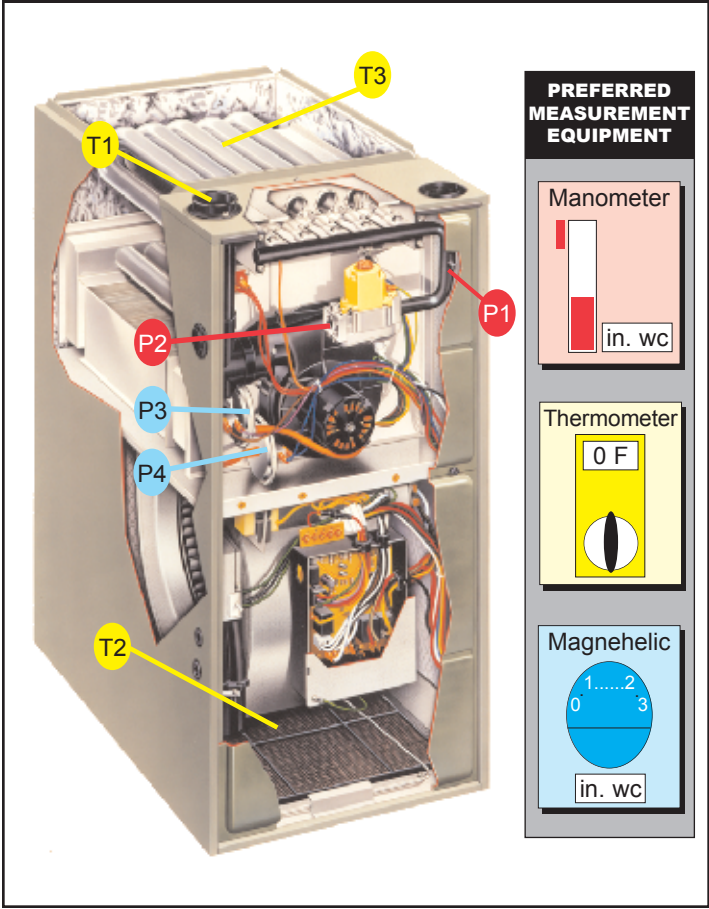

Figure 2

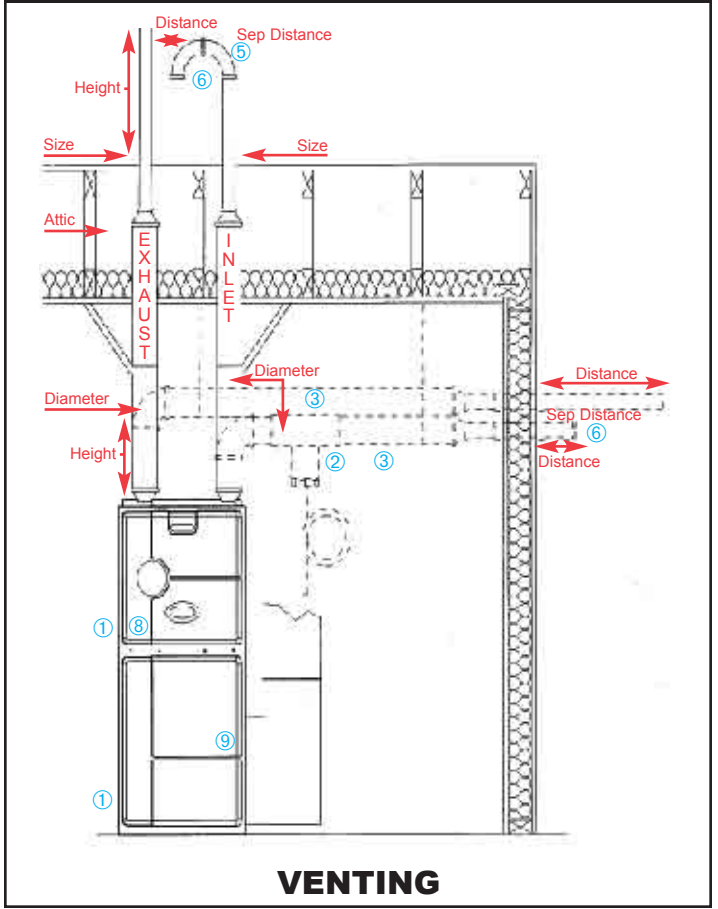

Figure 3

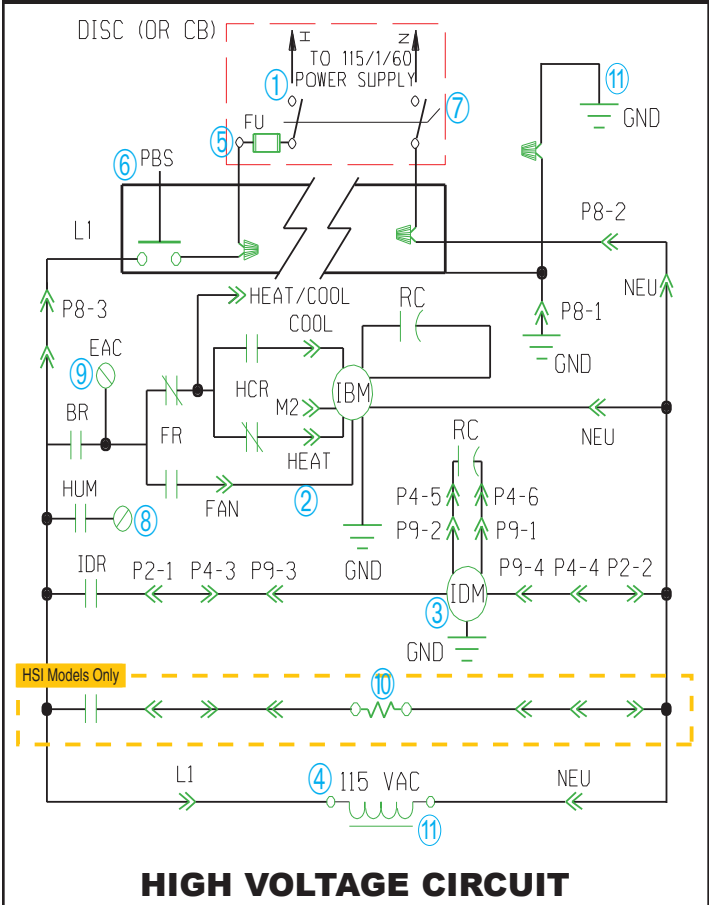

Figure 4

